

# In-Tank Pump DW100 (9-101)



The DW100 was designed as an OE replacement pump for your daily driver. The DW100 is based on the same fitment as the popular DW200 and DW300, but flows 165lph at 40psi to better fit the needs of your daily driver. In many cases, the DW100 will serve as a mild upgrade to the OE fuel pump. The DW100 features a quiet and reliable turbine impeller which is compatible with pulse width modulated pump drivers and an encapsulated armature for compatibility with ethanol based fuels. The DW100 fuel pump is are backed by a limited lifetime warranty.

## Specifications

<b>Weight</b>	12.6oz (360 grams)
<b>External Materials</b>	Electroplated Steel
<b>Inlet Fitting</b>	7.7mm ID, 11.0mm OD
<b>Outlet Fitting</b>	5/16" Hose Clamp
<b>PRV Activation</b>	100 psi
<b>Impeller Design</b>	Single Scroll Composite Turbine
<b>Connector Terminal</b>	Spade Pos/Neg
<b>Min Voltage Input</b>	6 Volts
<b>Max Voltage Input</b>	18 Volts
<b>Current Draw 40psi</b>	4.2 Amp (13.5v)

## Delivery Characteristics

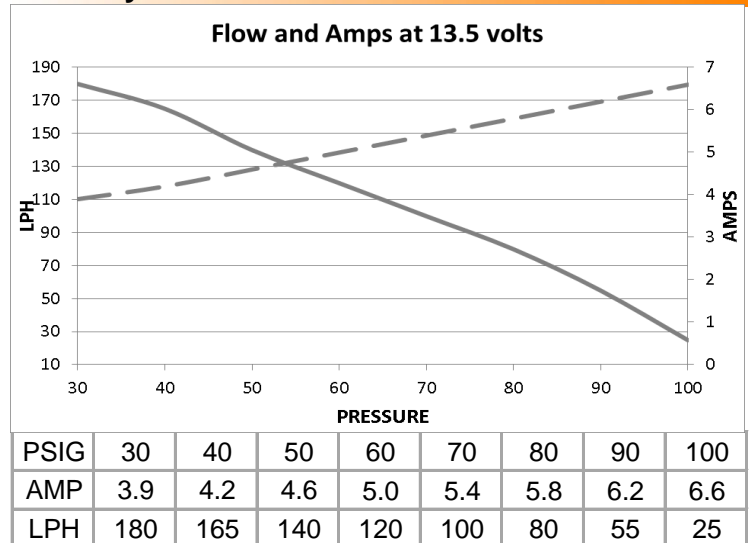

## Dimensions

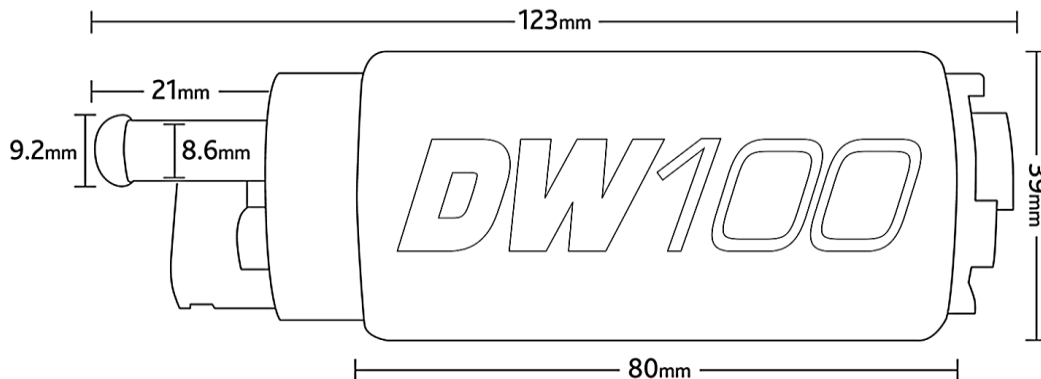

THIS PRODUCT MAY BE USED SOLELY ON VEHICLES USED IN SANCTIONED COMPETITION WHICH MAY NEVER BE USED UPON A PUBLIC ROAD OR HIGHWAY, UNLESS PERMITTED BY SPECIFIC REGULATORY EXEMPTION